

ECE 312 (SP26):

Hash Table

Neil Zhao

neil.zhao@utexas.edu

Revisiting Binary Search

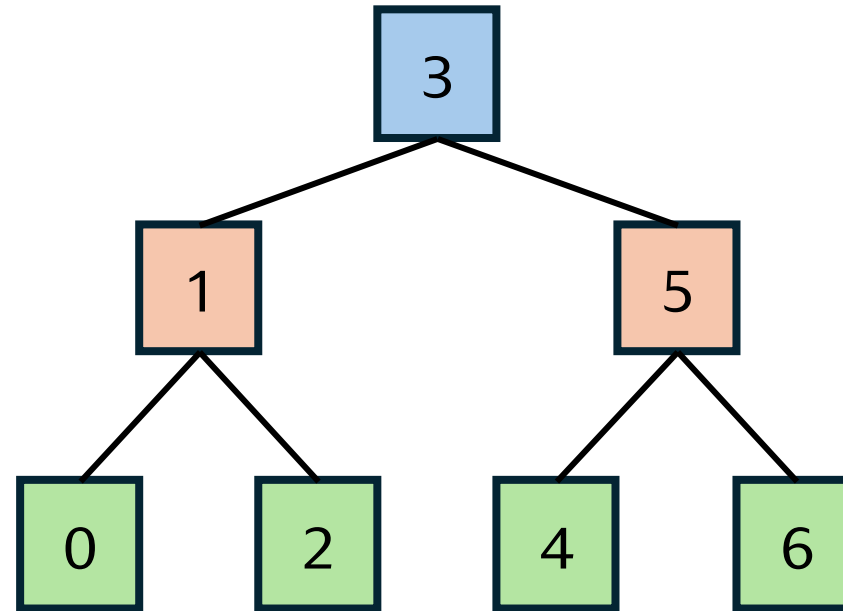

Complexity: $O(\log(N))$

Example: Finding if a Lowercase Letter is in a List

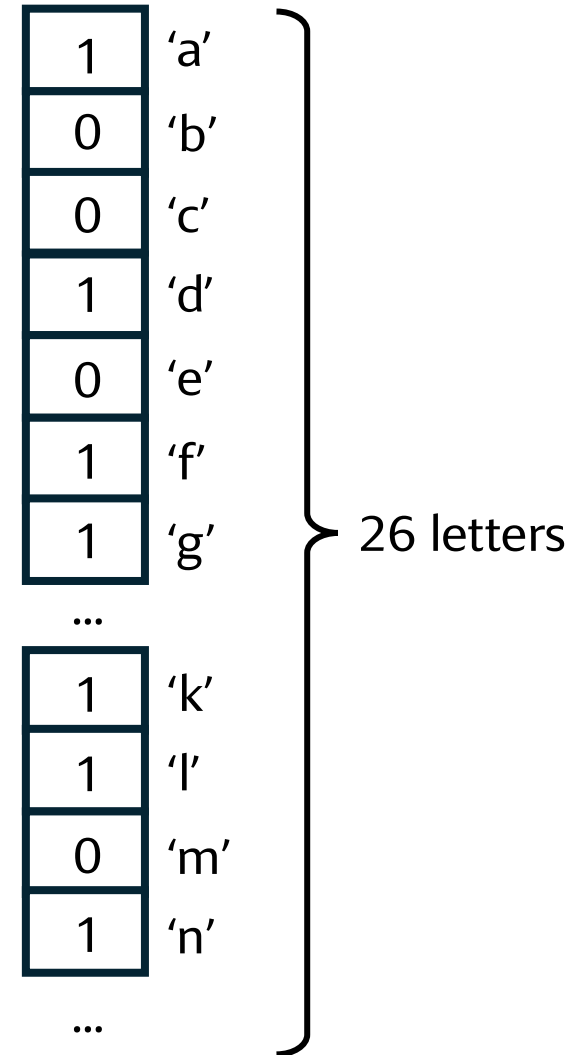
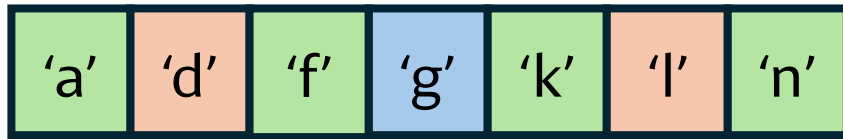

Example: Finding if a Lowercase Letter is in a List

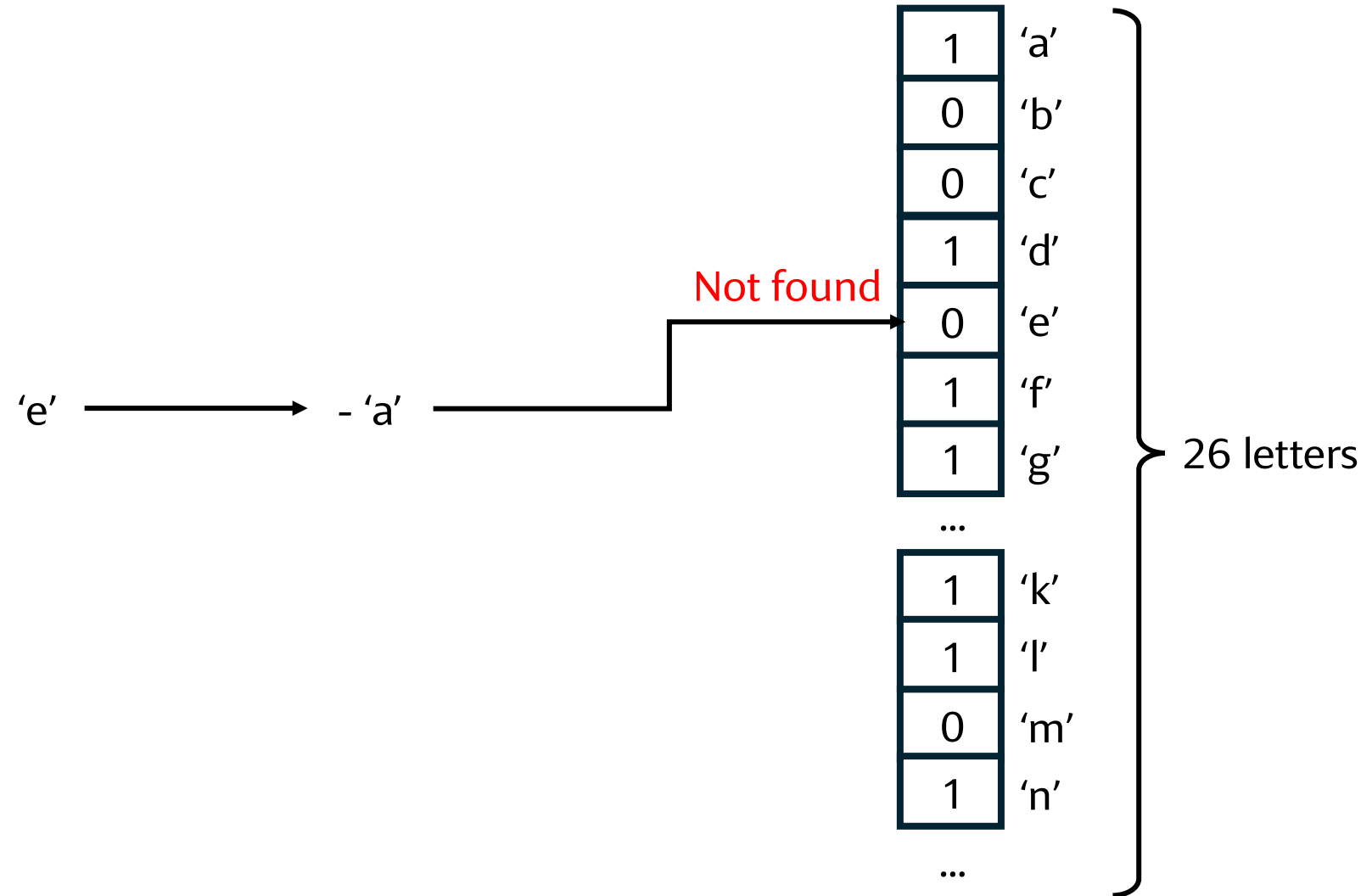

What if We Want to Do the Same Thing with a 32-bit Integer

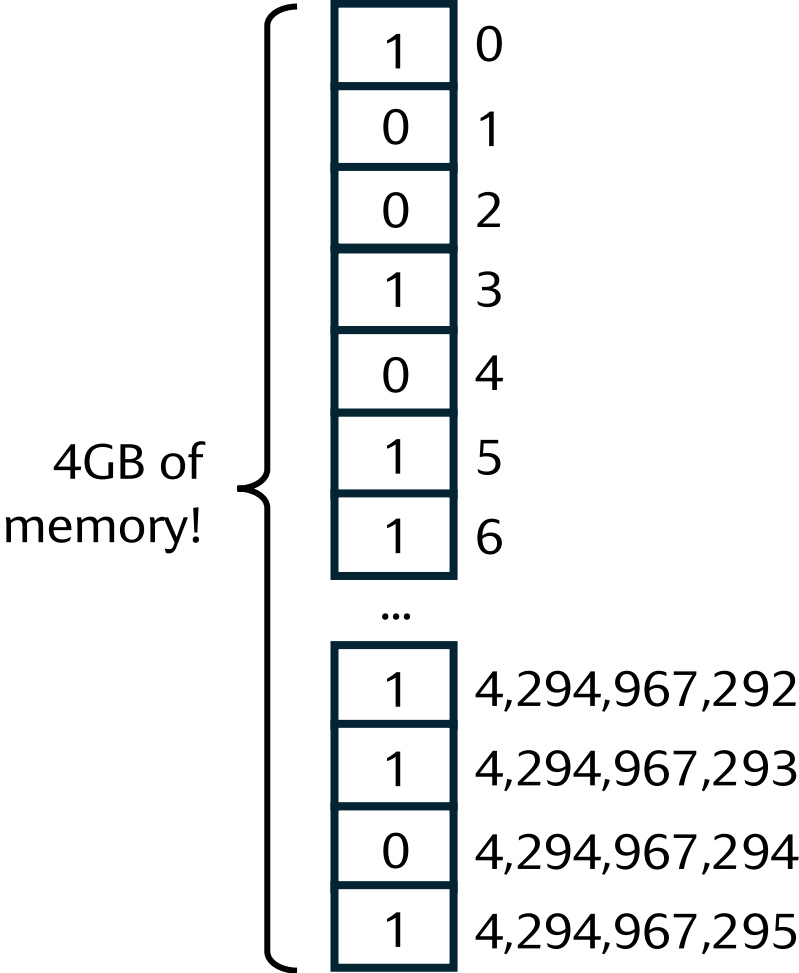

Hash Table

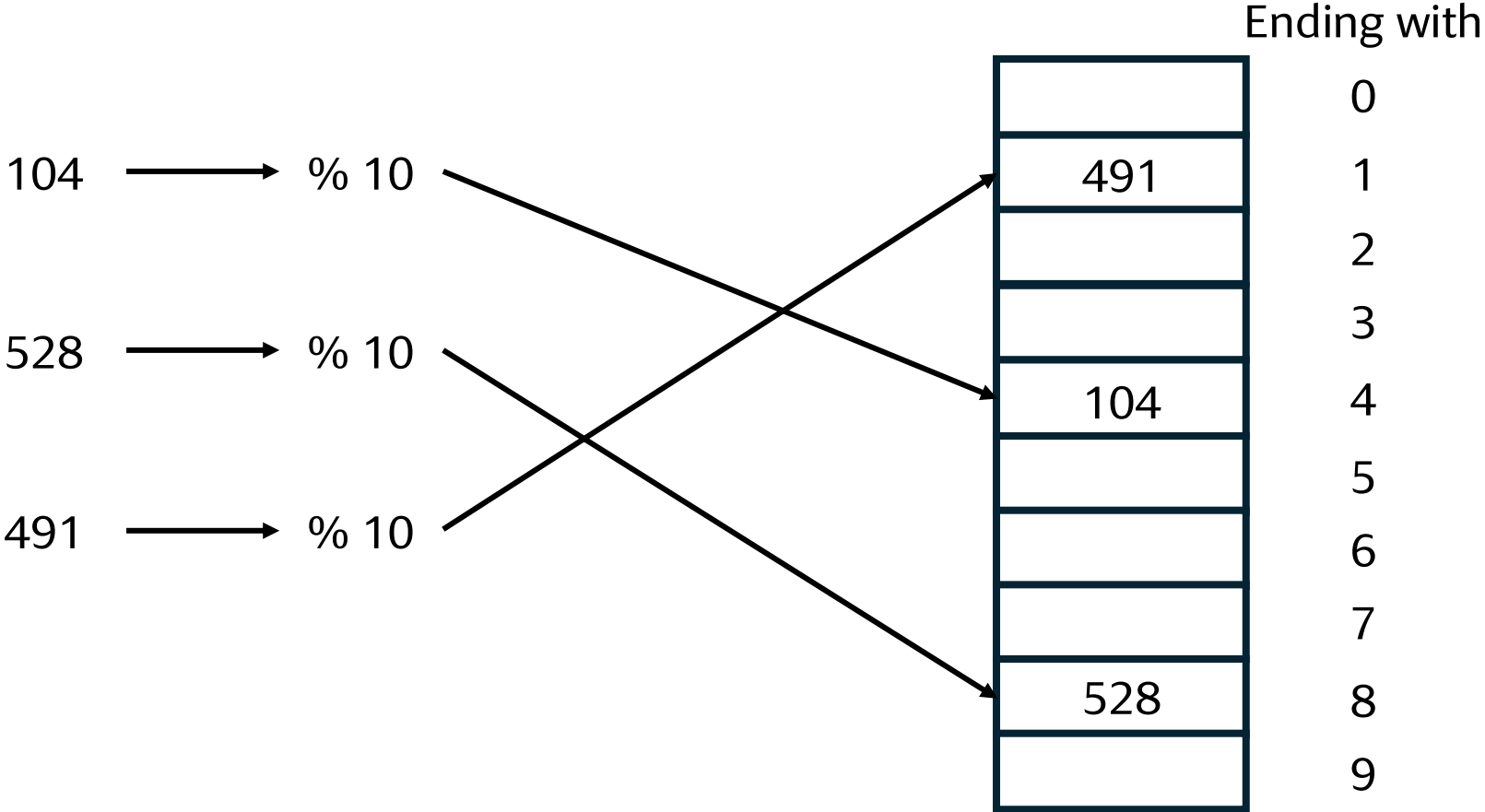

Hash Table - Collisions

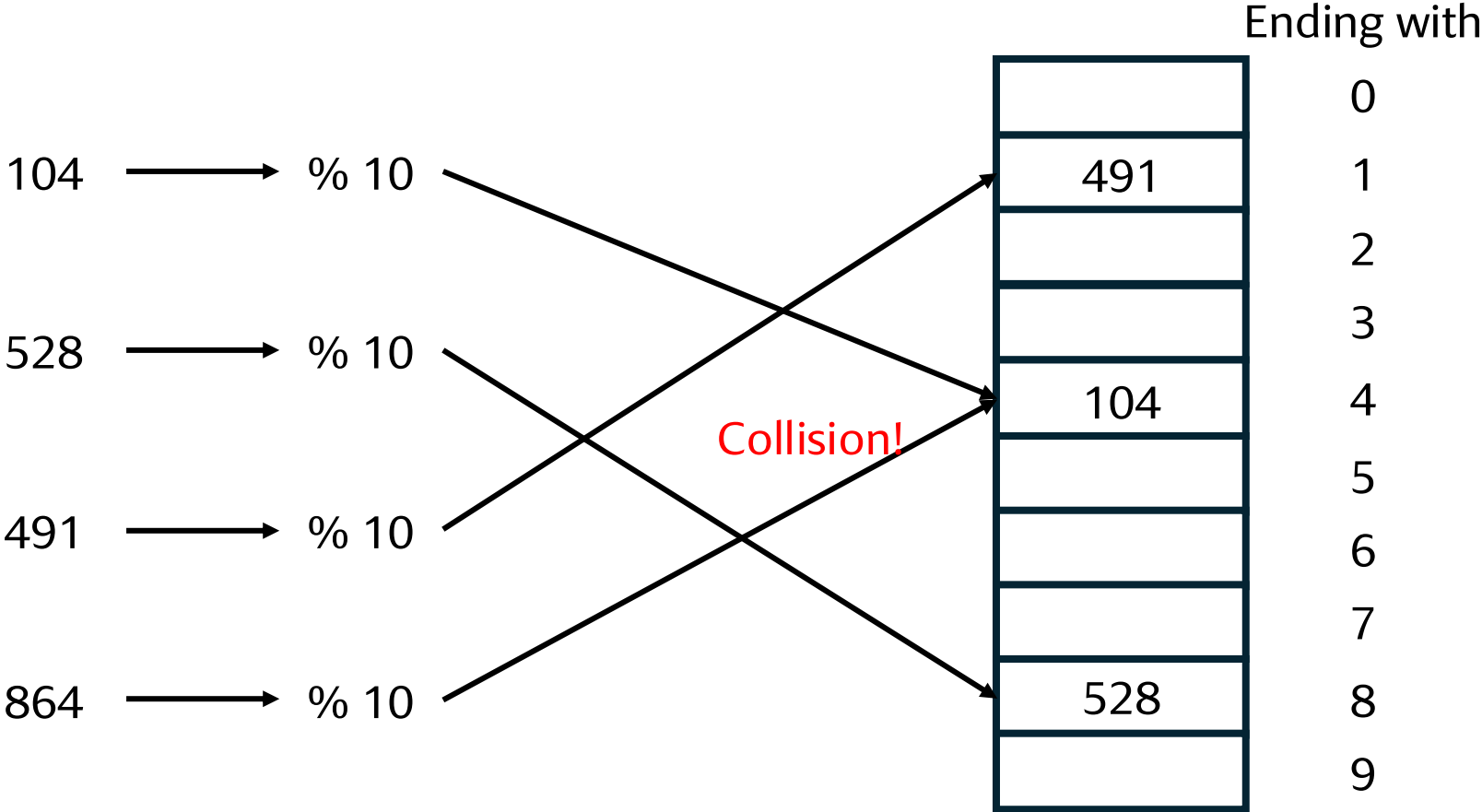

Hash Table – Resolving Collisions

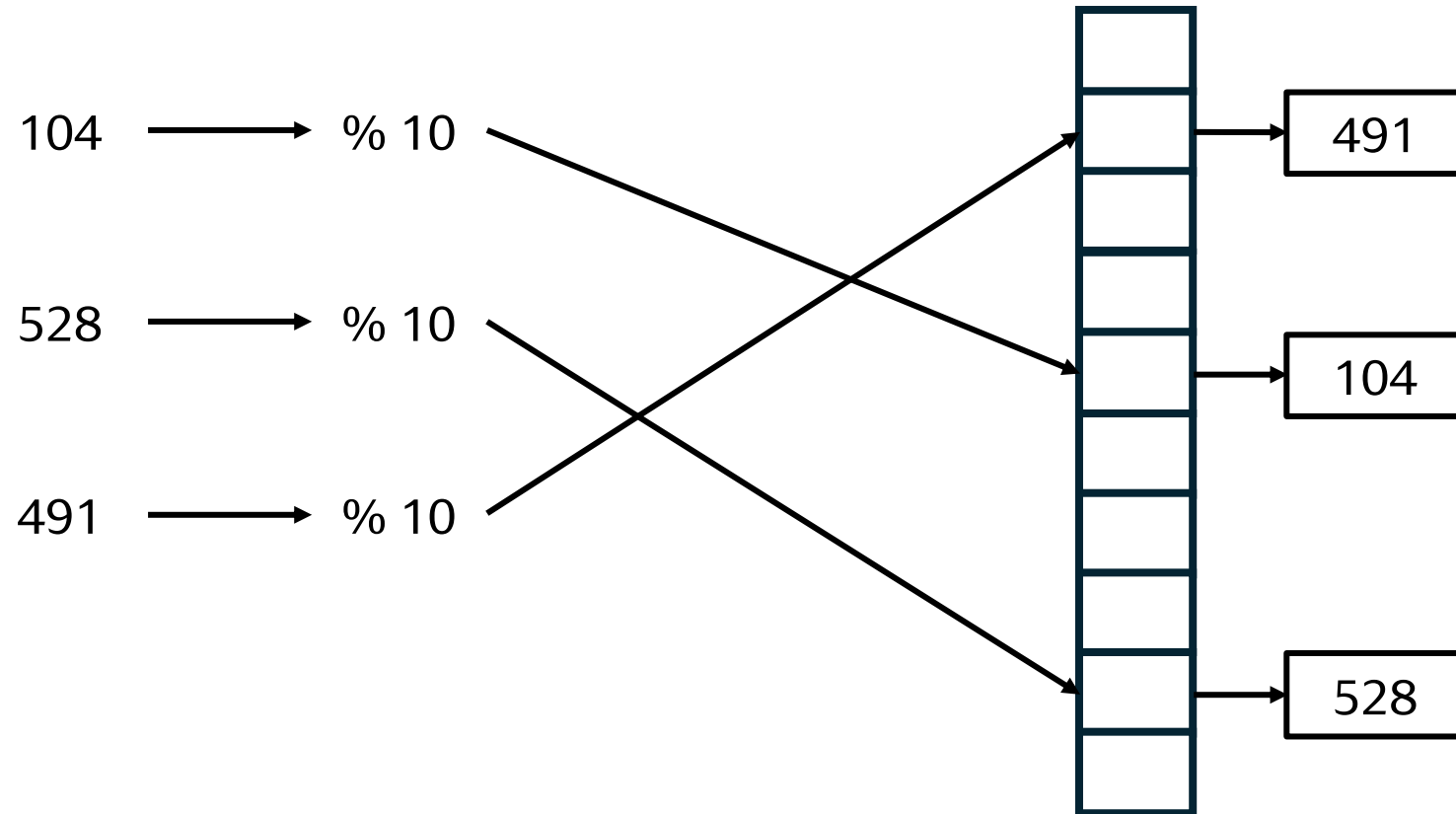

Hash Table – Resolving Collisions

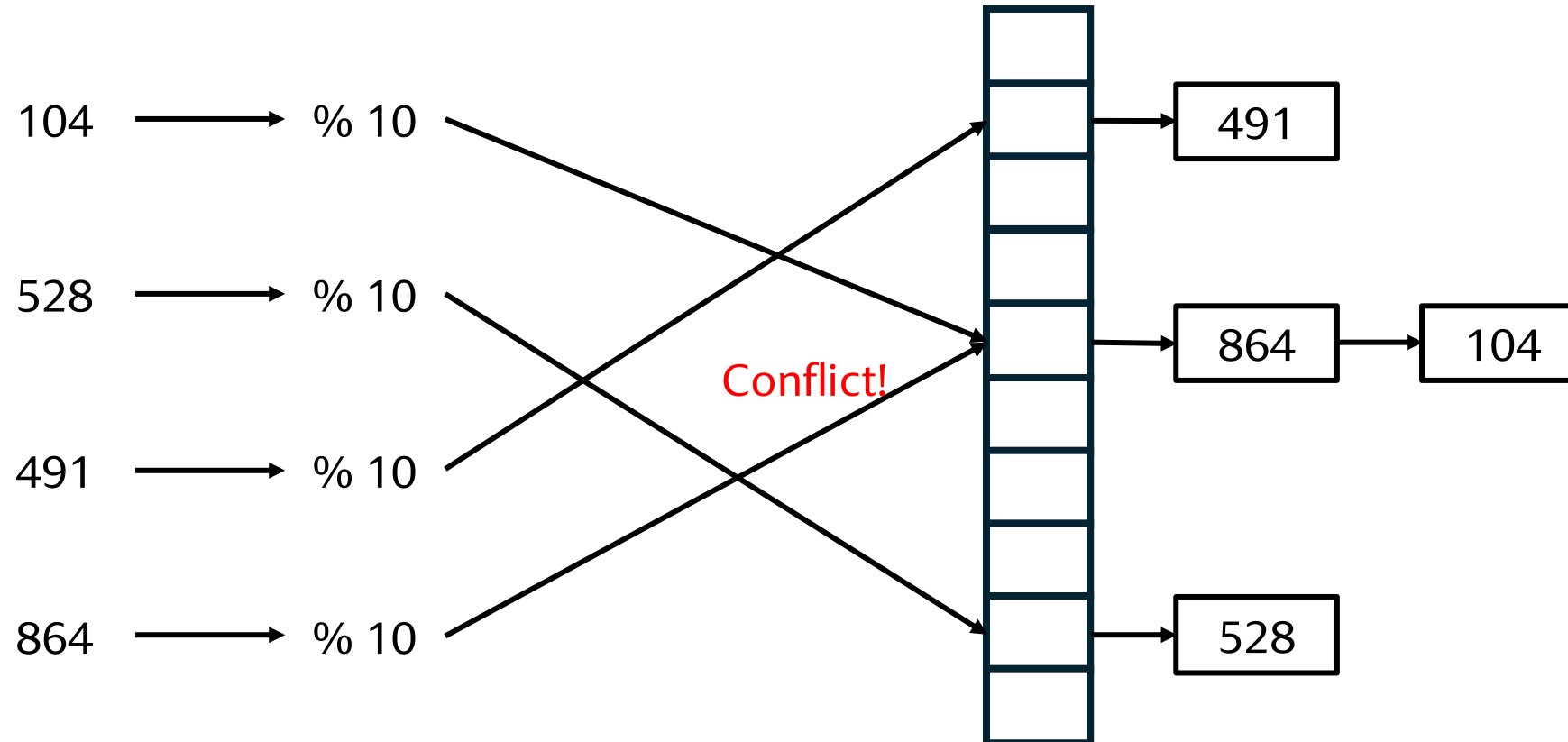

Hash Table – Lookup

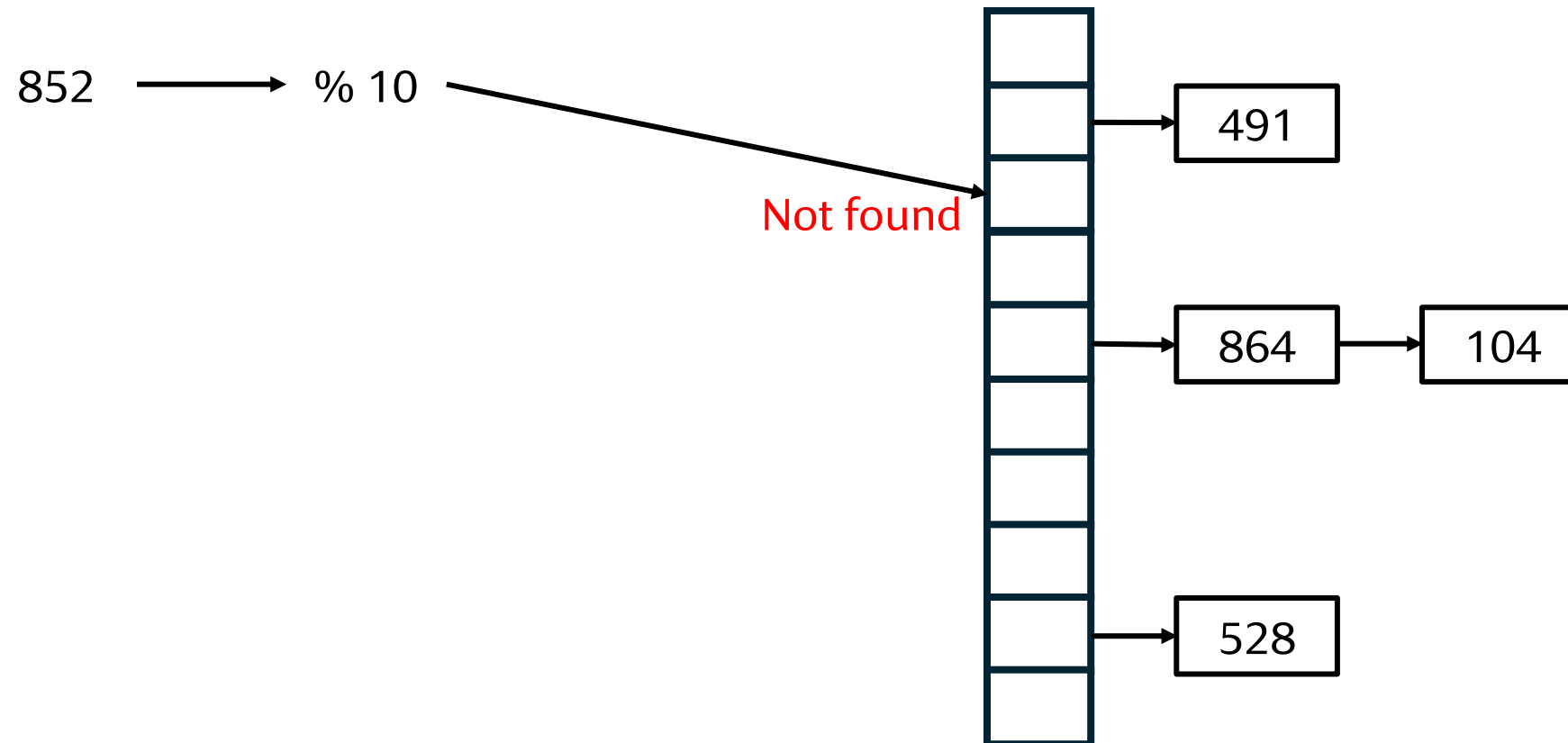

Hash Table – Lookup

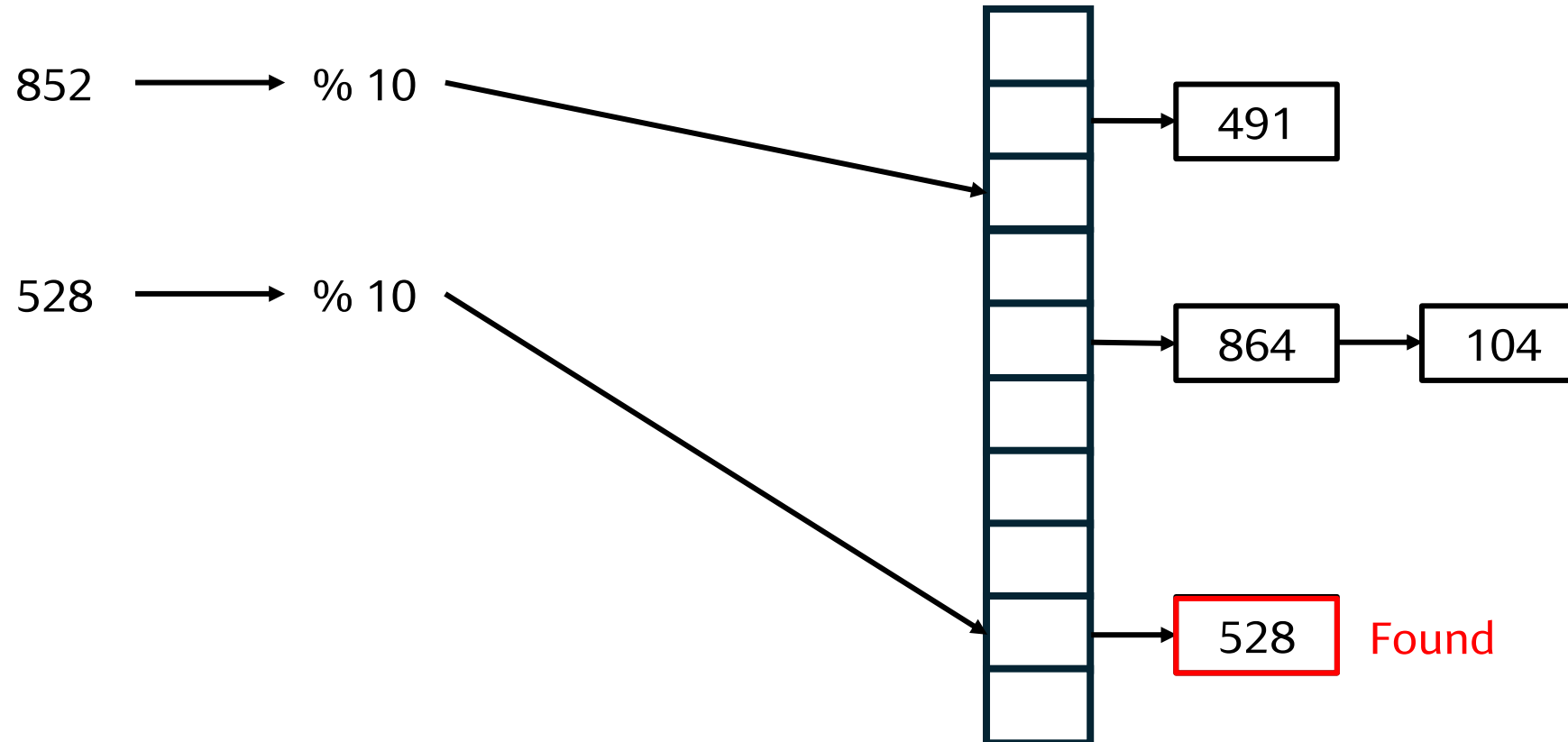

Hash Table – Lookup

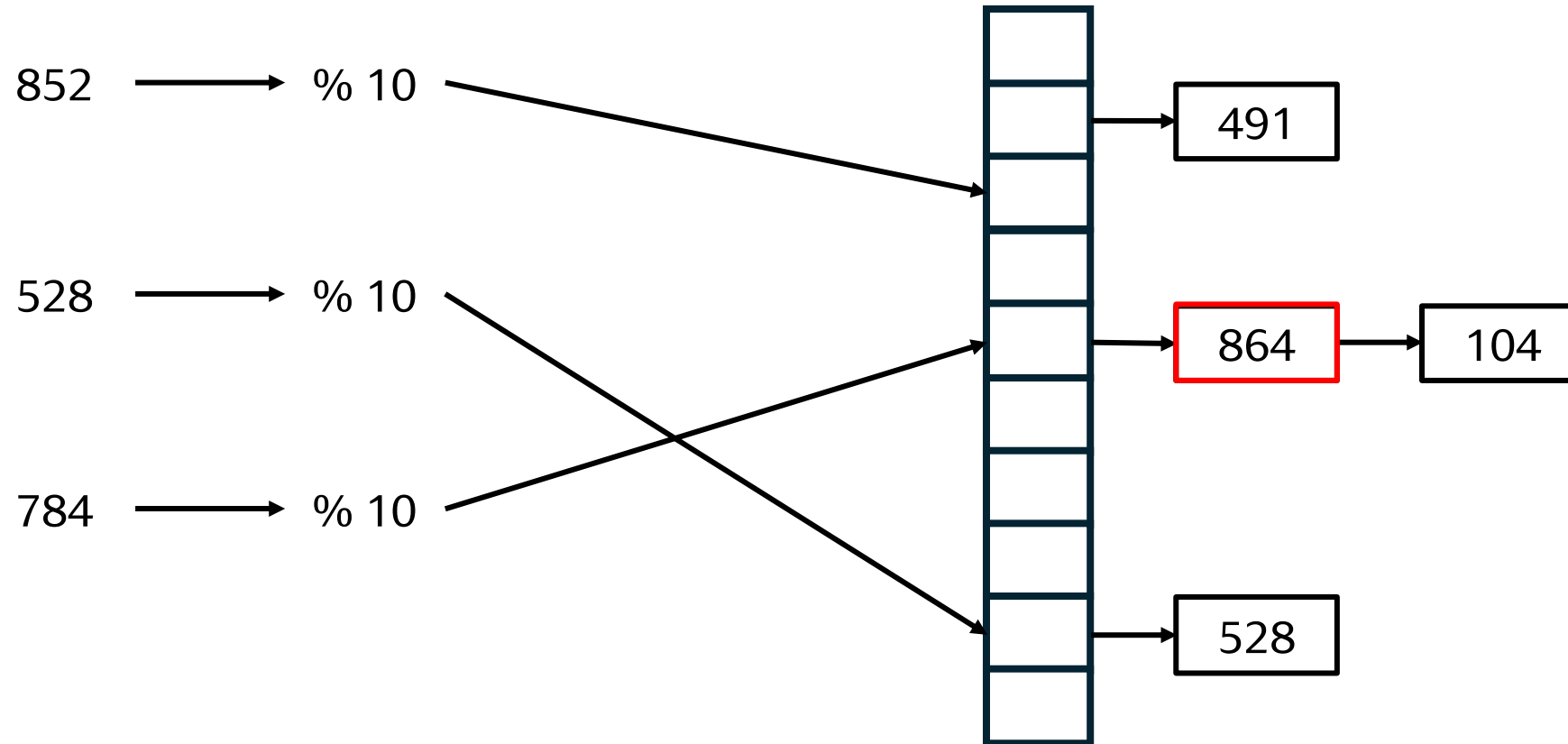

Hash Table – Lookup

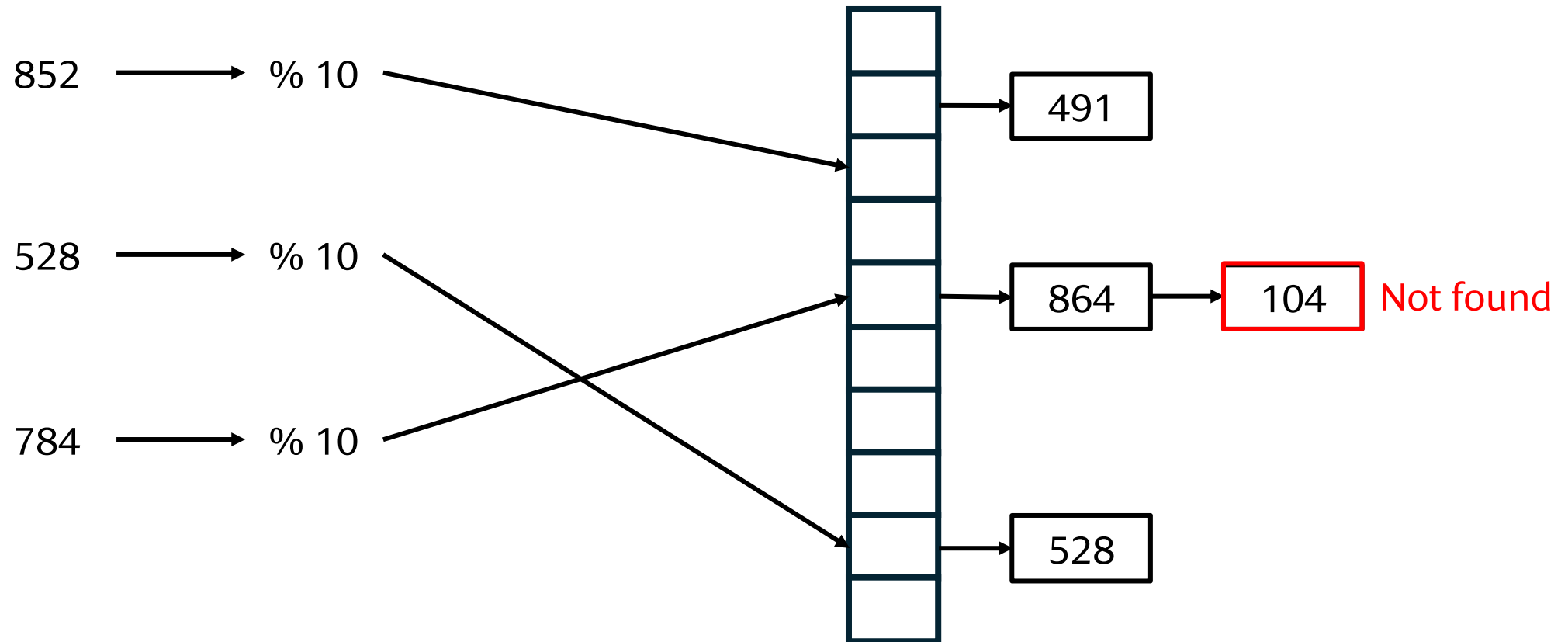

Best case: $O(1)$, Worst case: $O(N)$

Hash Table – Reducing Collisions

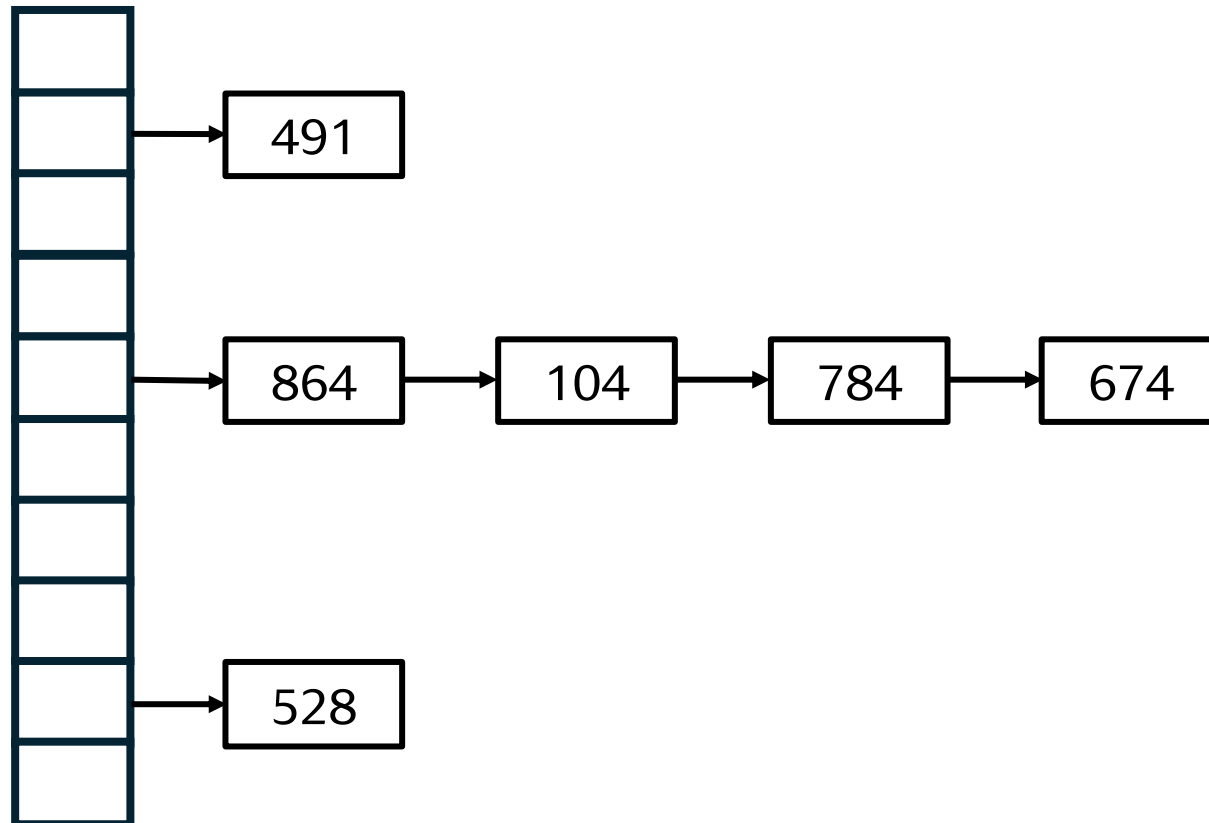

Hash Table – Reducing Collisions

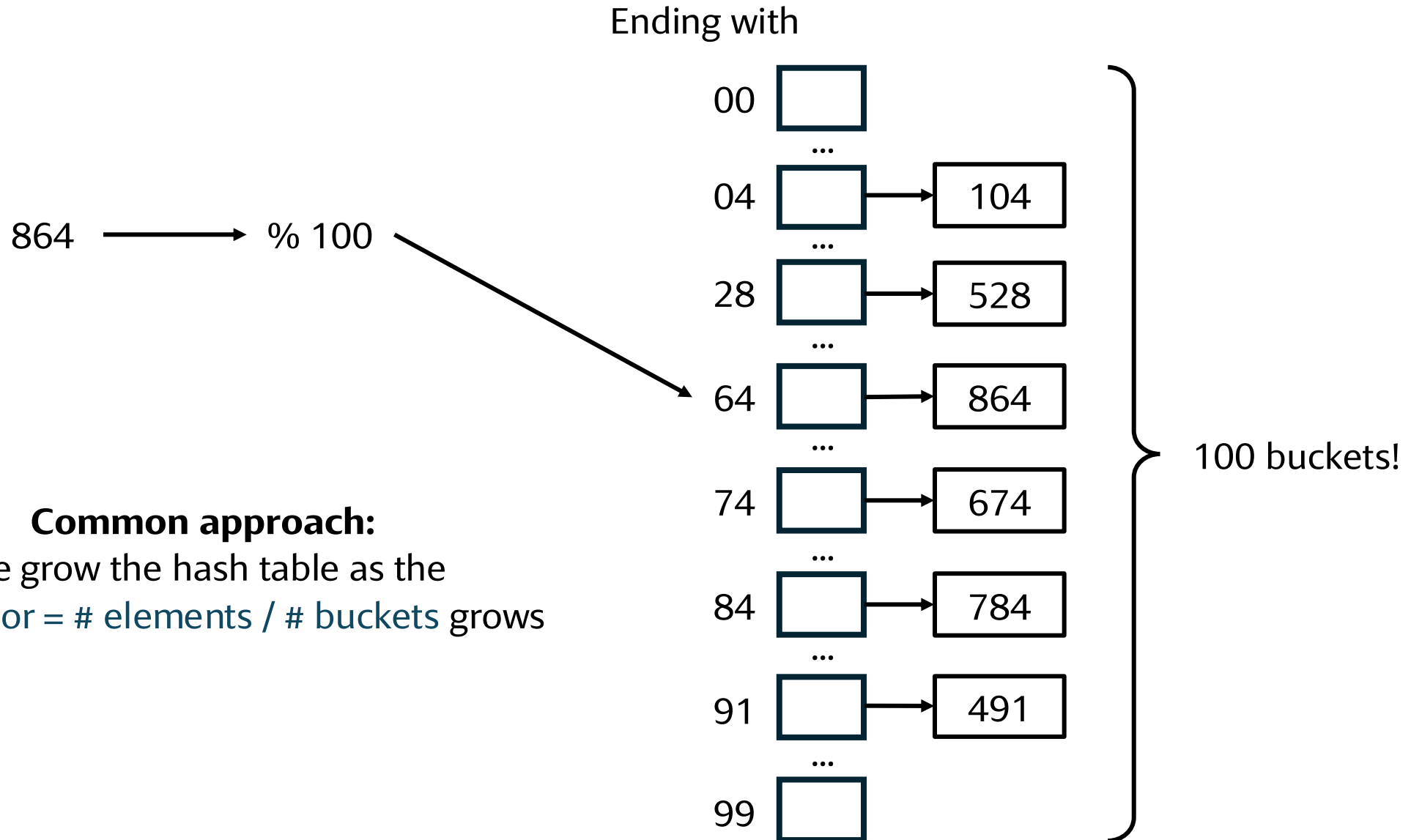

Resolving Collisions – Open Addressing (Linear Probing)

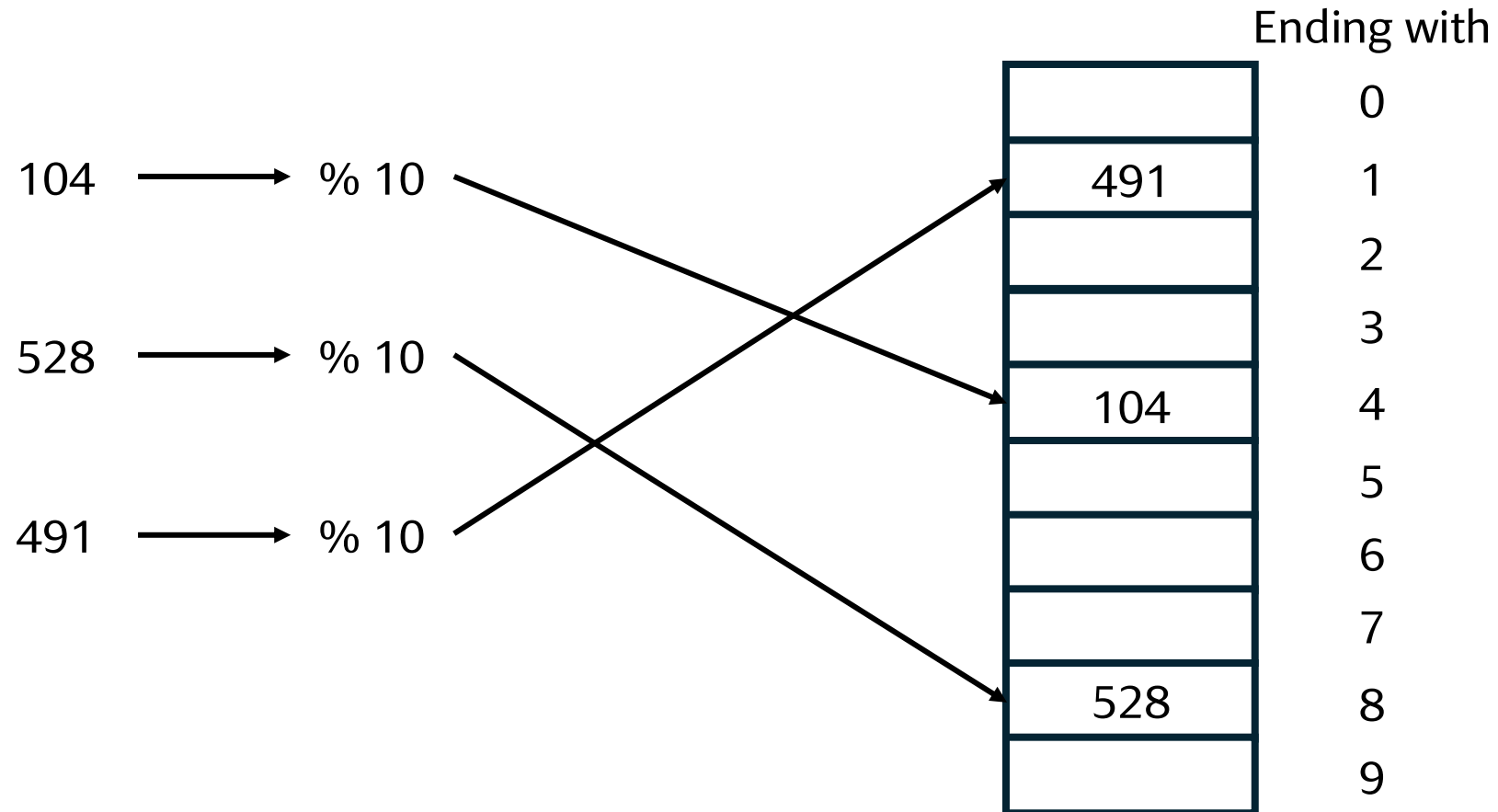

Resolving Collisions – Open Addressing (Linear Probing)

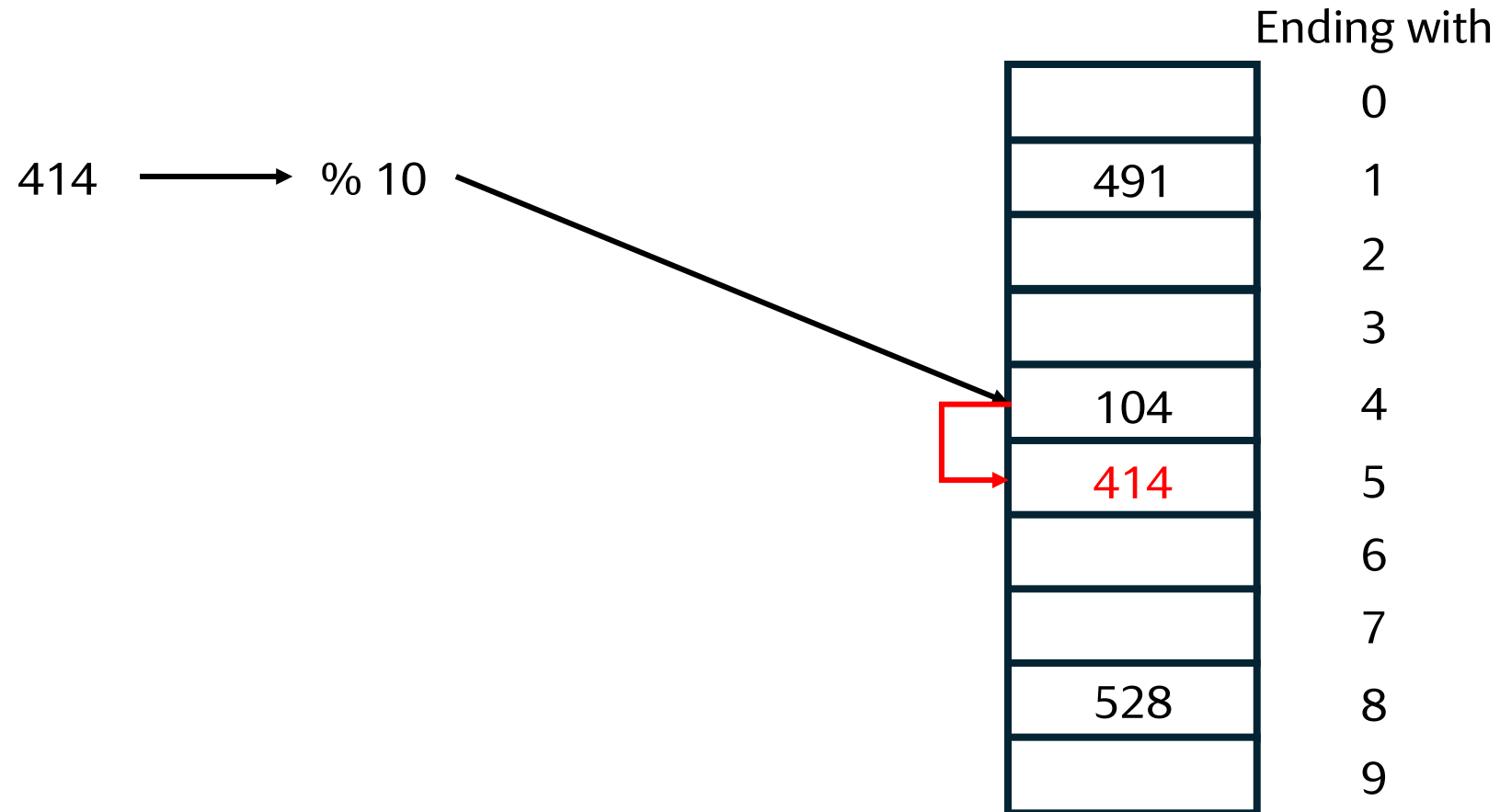

Resolving Collisions – Open Addressing (Linear Probing)

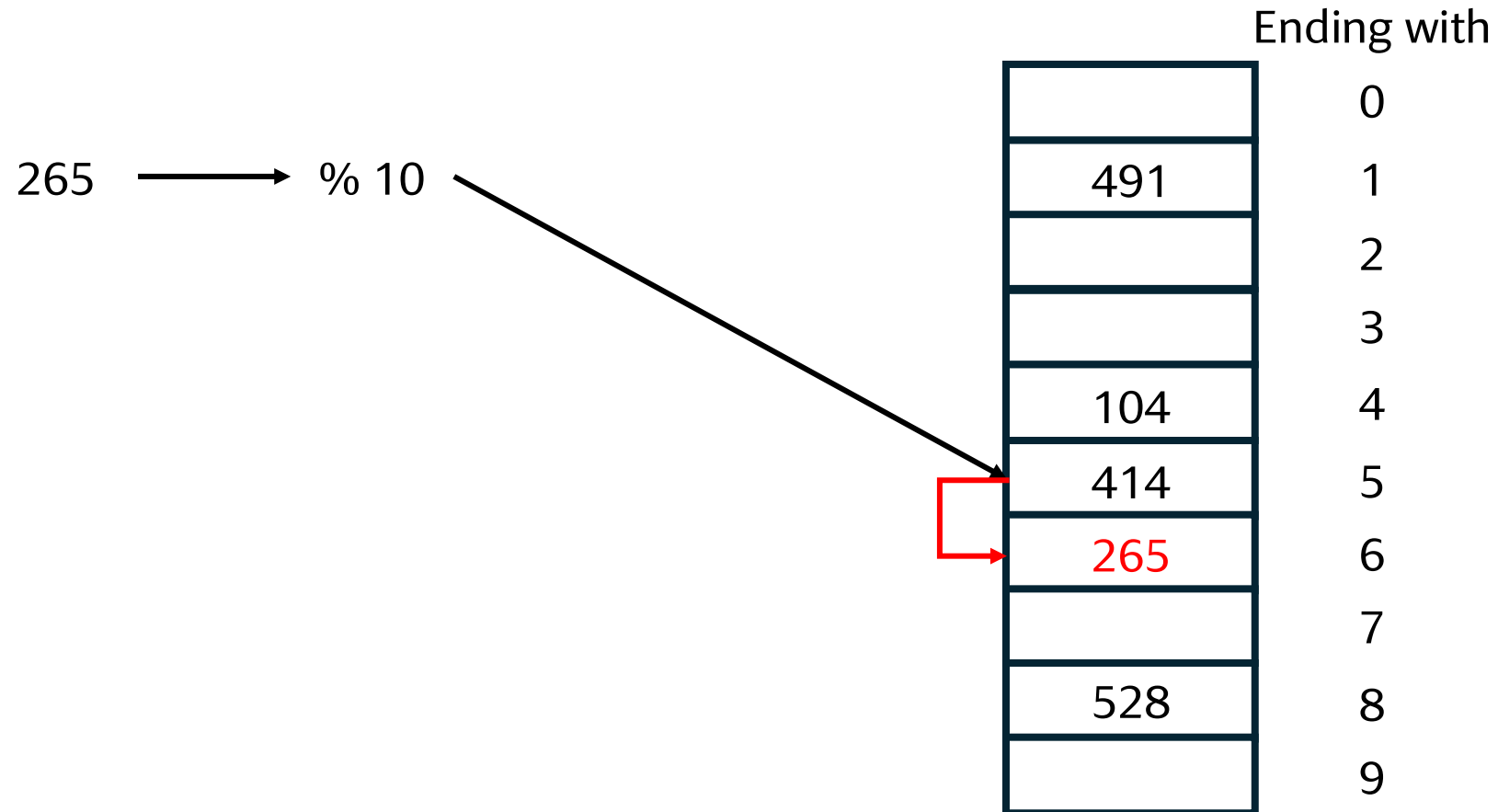

Resolving Collisions – Open Addressing (Linear Probing)

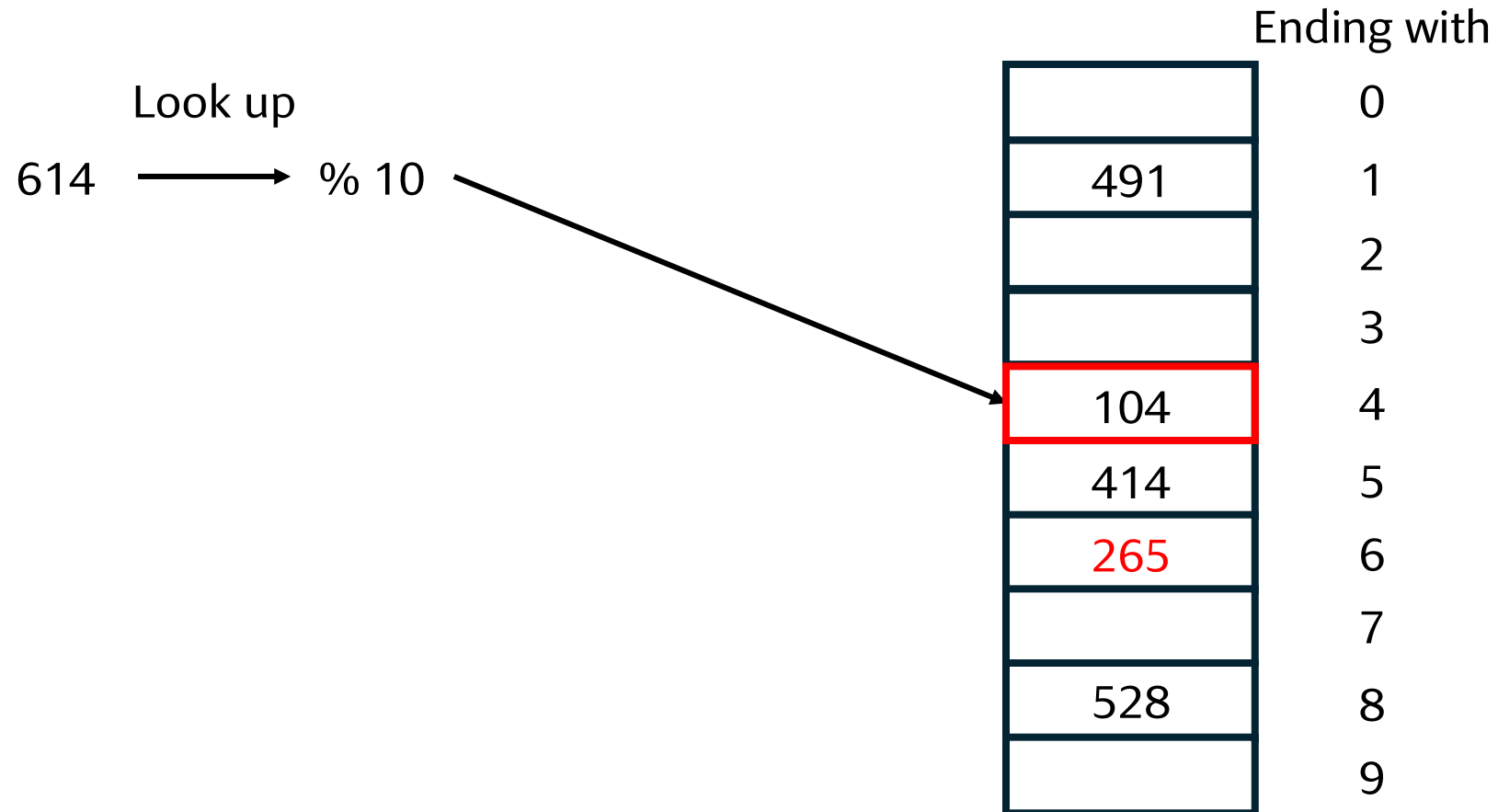

Resolving Collisions – Open Addressing (Linear Probing)

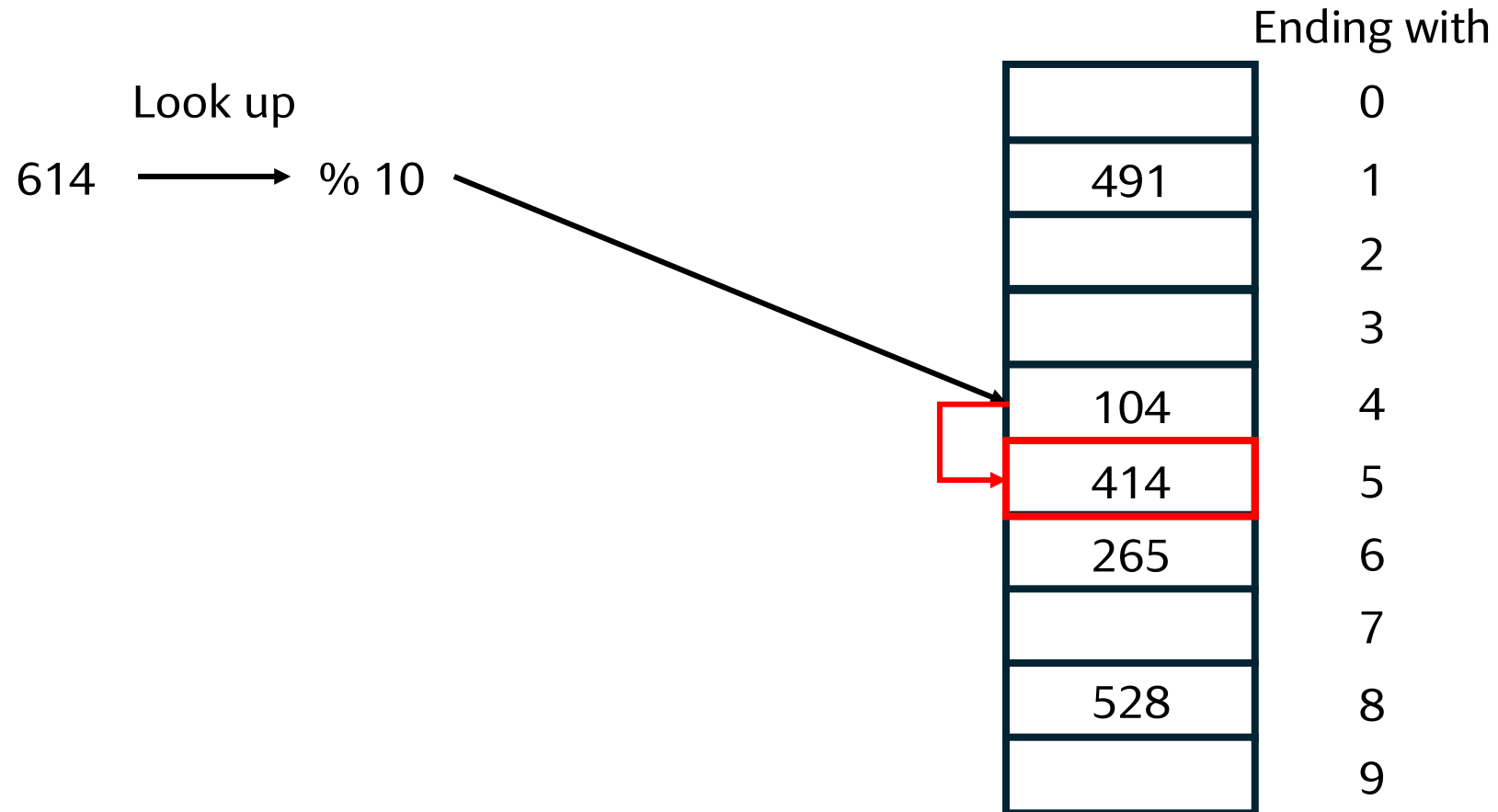

Resolving Collisions – Open Addressing (Linear Probing)

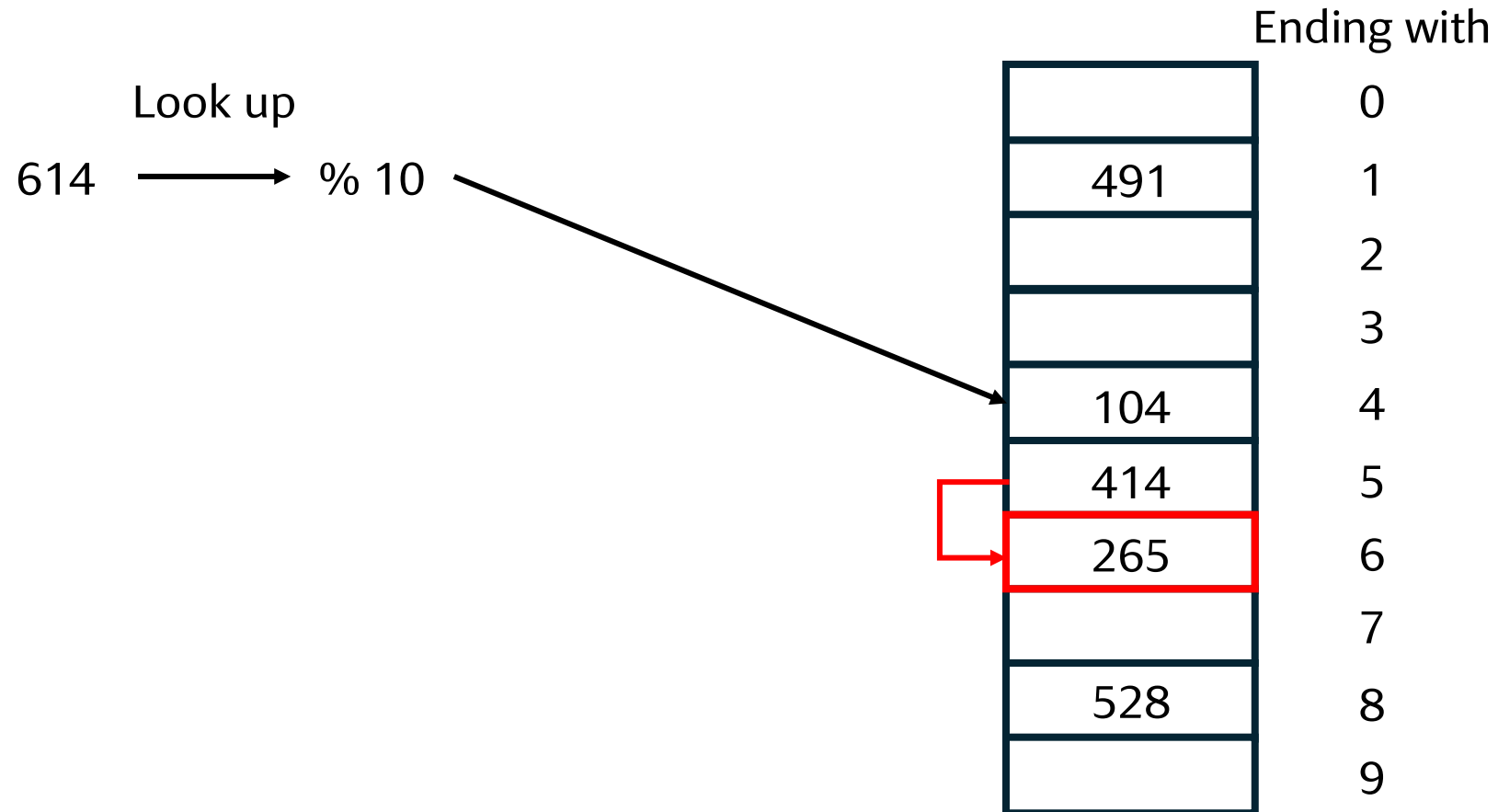

Resolving Collisions – Open Addressing (Linear Probing)

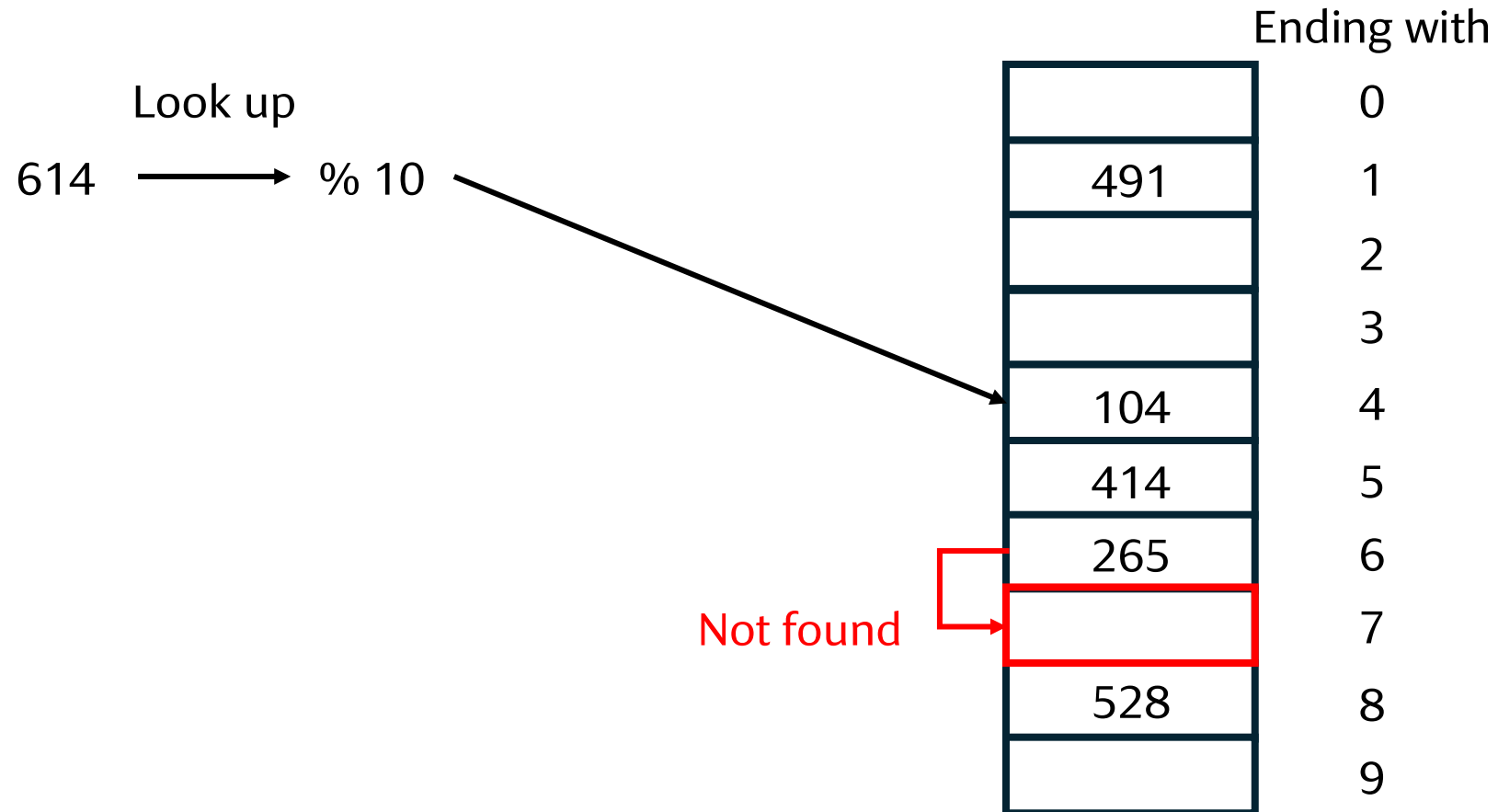

Open Addressing – Deletion (Linear Probing)

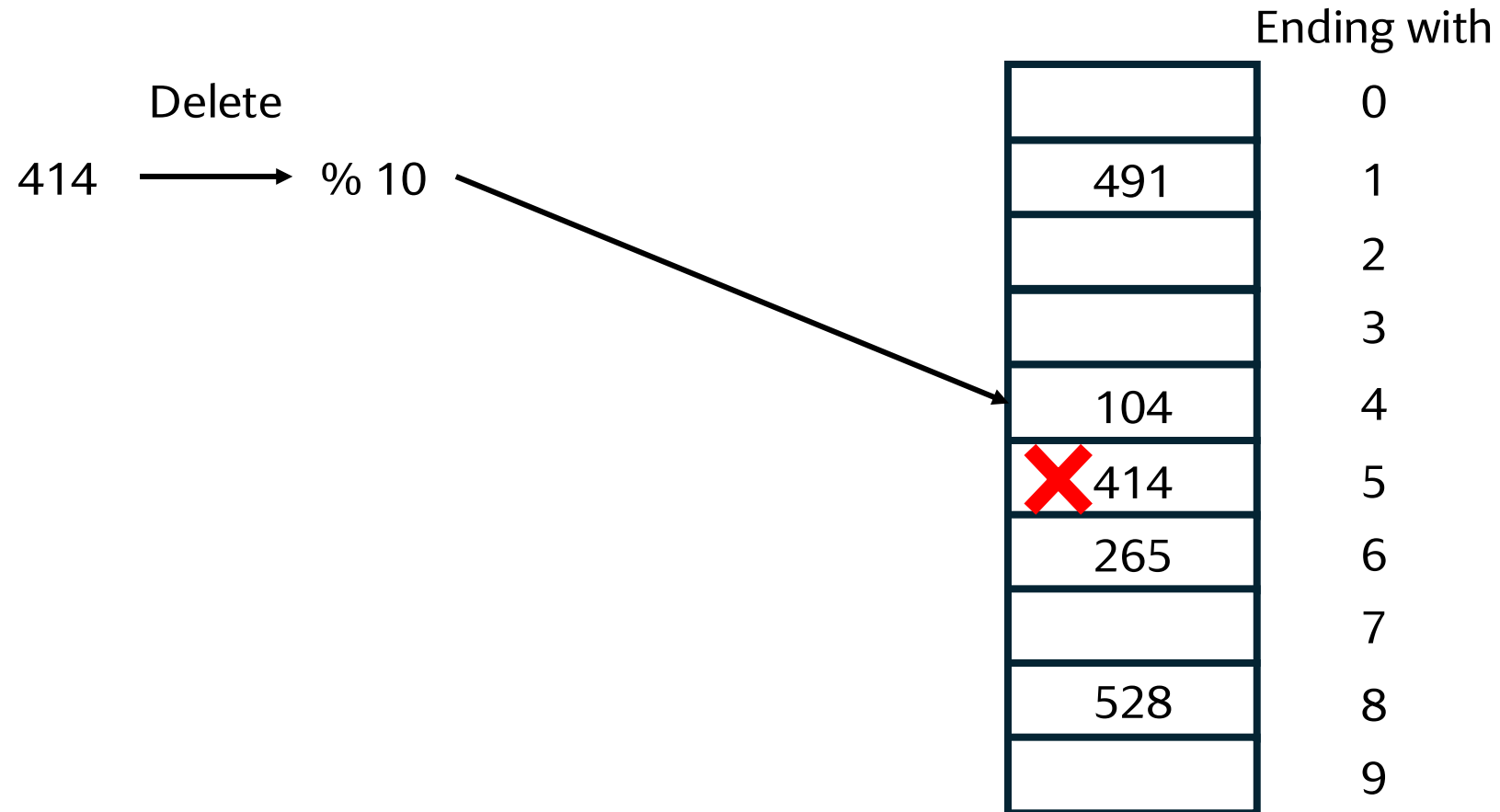

Open Addressing – Deletion (Linear Probing)

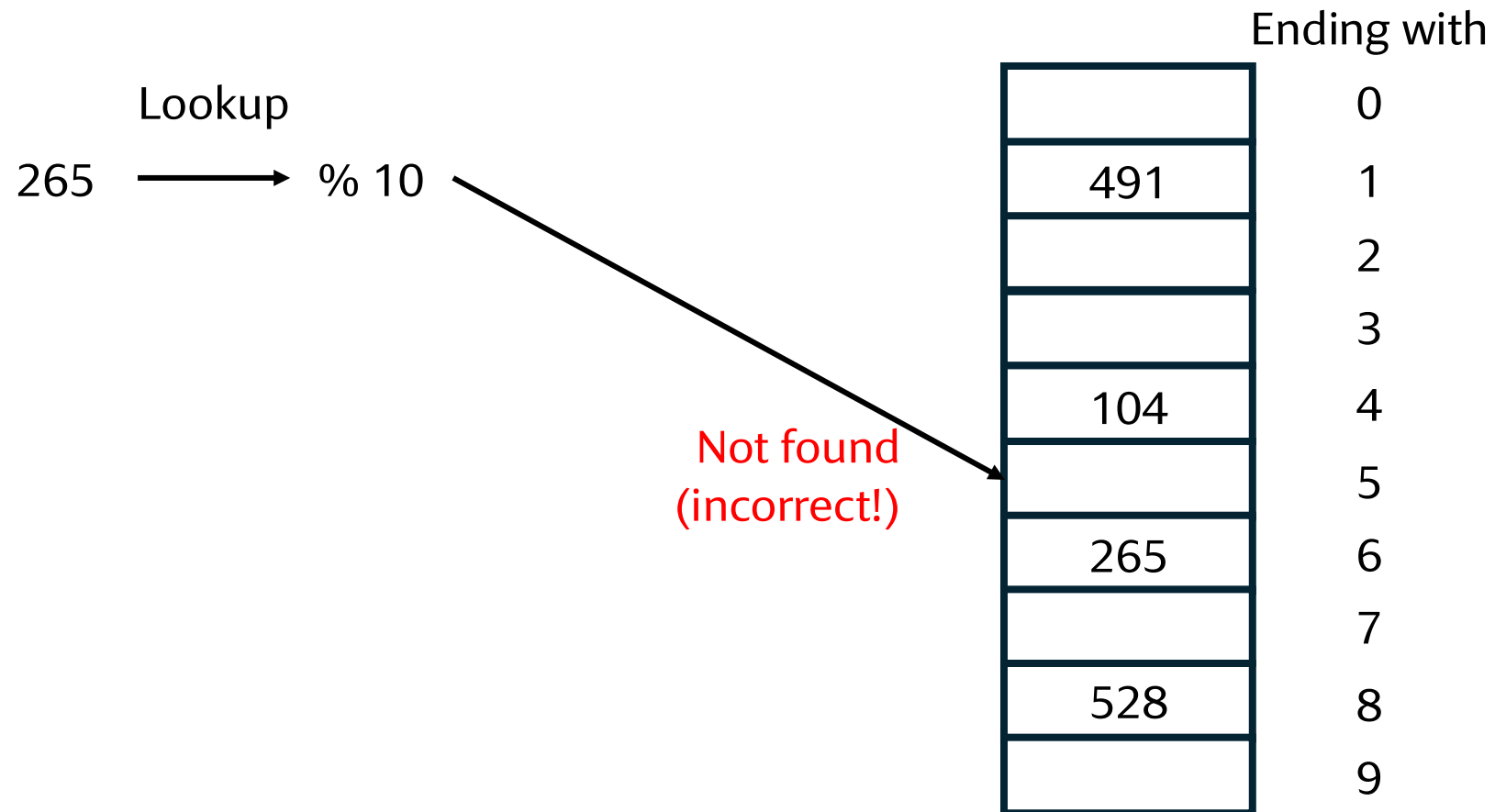

Open Addressing - Tombstone

